



CORPORATE PRESENTATION
THE WAYTRONX OPPORTUNITY

Forward-Looking Statements

This document contains forward-looking statements within the meaning of Section 27A of the Securities Act of 1933, as amended, and Section 21E of the Securities Exchange Act of 1934, as amended. Such statements are subject to risks and uncertainties that could cause actual results to vary materially from those projected in the forward-looking statements. The company may experience significant fluctuations in future operating results due to a number of economic, competitive, and other factors, including, among other things, our reliance on third-party manufacturers and suppliers, government agency budgetary and political constraints, new or increased competition, changes in market demand, and the performance or reliability of our products. These factors and others could cause operating results to vary significantly from those in prior periods, and those projected in forward-looking statements. Additional information with respect to these and other factors, which could materially affect the company and its operations, are included in certain forms the company has filed with the Securities and Exchange Commission.

WAYTRONX, INC. COMPANY OVERVIEW

- **Headquarters – Tualatin, OR**
- **Worldwide offices [Employees]**
 - Tualatin, OR [50]
 - Limhamn, Sweden [3]
 - Shenzhen, China [4]
 - Safety Harbor, FL [1]
 - Japan [26]
 - *Total Employees – 84*
- **Trading Symbol: WYNX:OTC**



WAYTRONX INC. | Global Presence

Tualatin, Oregon



Functions: quality control, R&D, sales, and logistics

Limhamn, Sweden



Functions: sales, and logistics

Tokyo, Japan



Functions: quality control, R&D, quality sales, and logistics

Shenzhen, China



Functions: R&D, and supplier

Manufacturing Locations:

China, Japan, Taiwan, South Korea

WAYTRONX, INC. – 2009 INITIATIVES

- **CUI, Inc.**
- **Technology Initiatives**
 - Digital Power Modules
 - AMT Encoder
 - C14 Encoder
- **CUI – Japan**
- **Sales Expansion**
- **R&D Initiative**
- **Waytronx – GL Industrial Services [Advantica Ltd.] Business Unit**
 - GASPT2

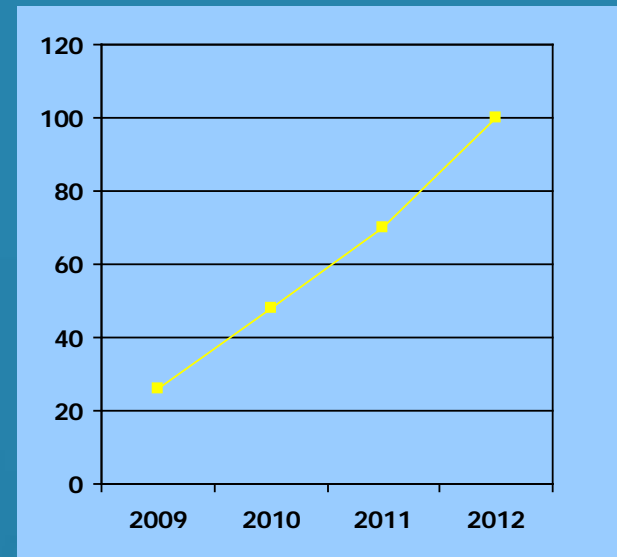

CUI, INC.

PRODUCT LINES & SERVICES

CUI offers six distinct product lines:

- External power: linear and switching power supplies
- V-Infinity: internal power supplies
- Thermal: Peltier devices, heat sinks
- Sound: buzzers and speakers
- Control: encoders and sensors
- Interconnect: connectors and custom cable assemblies



Services:

- Customization
- global sourcing
- specification access/3D modeling
- application support
- in-house testing
- customized shipping services



CUI MAJOR CUSTOMER LIST



PHILIPS

Microsoft

OPEN PEAK

KOHLER

Electrolux

Honeywell



DANAHER



CUI PRODUCT | Sales breakdown

2008 Revenue by Product Group

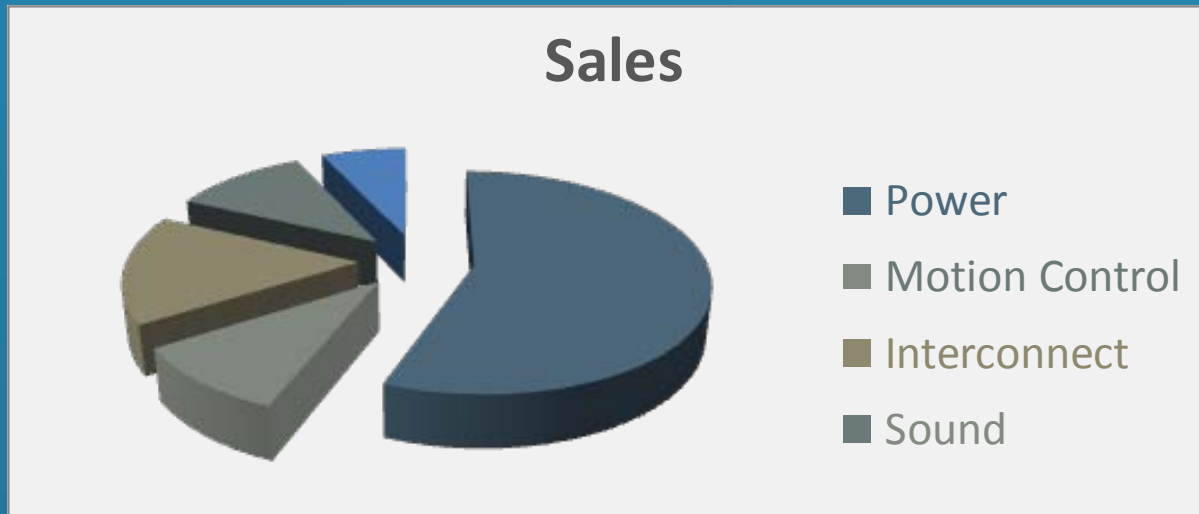

TECHNOLOGY INITIATIVES [DPM]

- **Digital Power Market**

- Proprietary Nature
 - Patented Chip Technology
 - Strategic partnership – Power One & Powervation
 - Flexibility | Cost | Configuration | Power Monitoring | Power on Demand | Built in Self-Test (BIST)
 - Efficiency & Reduced use of power [Green Initiatives]; performance gains; design flexibility
- Target Customers
 - Tier 2 & Tier 3 Telecom/LED OEM's
 - Juniper Networks; Google server applications; design in rack
- Commercialization
 - Production & Delivery 1st Quarter 2010

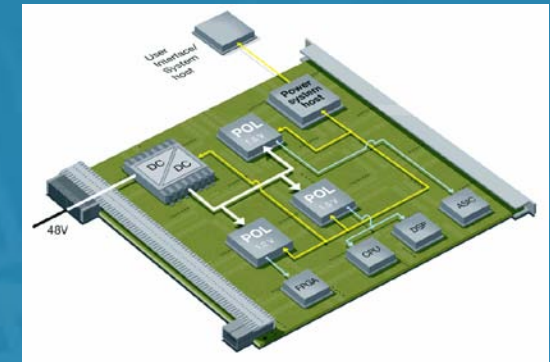

TECHNOLOGY INITIATIVES [AMT]



- **DANAHER**

- Co-branding opportunity – DC Motors
- Pursuing broad introduction of proprietary encoder
 - Increasing sales



ANNUAL REPORT 2006

- **DIEBOLD**

- Design win – ATM Cash Machines
 - ASP \$18.90



- **Micromo**

- Design win – Electric motors
 - GM Electric seats & joint venture
 - ASP \$16.00

TECHNOLOGY INITIATIVES [C14]

- **IP Participant**

- Directly competitive with Grayhill encoders
- ASP \$10.00 to \$12.00
- 40+% gross margin



- **Encoder**

- CUI owns exclusive rights
- Full production began First Quarter 2009

- **Opportunity**

- Grayhill currently has market cornered
 - Poor customer service & technical support
- Multi-million dollar market opportunity – \$10.0 mm line upon maturity
- Current identified customers already requesting delivery
- Next generation ultra-sound with Phillips

CUI – JAPAN

- **Current Business**

- Comex International; Comex Electronic; & Fox Distribution
 - Japan Rail; Japan Defense Force; Mitsubishi; Toshiba; Sony; Fujitsu; Honda
 - Manufacturing component – Engineering Team

- **Access to Japanese Market**

- Significant product penetration with local presence
- \$1.0 mm in revenue Third Quarter 2009



SALES EXPANSION

- **Vertical Expansion**

- Rep Organizations

- Seven (7) new rep groups signed on immediately

- 74 additional sales executives

- » 39 Electrical Engineers

- » 5 Other Engineering Degrees

- Majority of North America covered + Mexico, Puerto Rico, NW/W Canada

- Two exclusive organizations in Europe

- Independent Contractors

- Strictly commission based compensation

- No immediate impact SG&A

R&D INITIATIVES: WayCool™ - *3C for 3D*

WayFast™ Fabric *Communications*

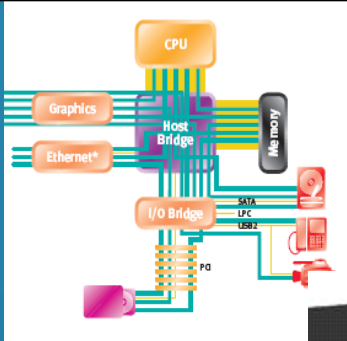

Electrical *Current* delivery

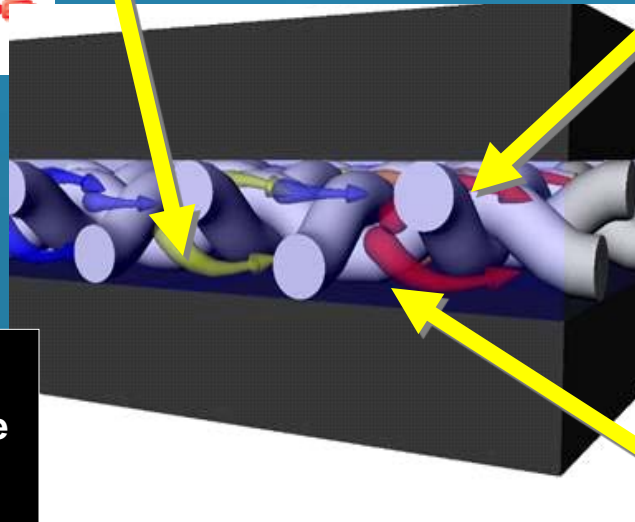

3-D packaging

- Smaller, faster, more reliable systems
- For CPU/GFX, memory, and SOC

WayCool™ *Cooling*

R&D INITIATIVES: DARPA

- **Defense Advanced Research Projects Agency (DARPA)**
 - Develops new technology for use by the U.S. Military
 - Internet
 - Stealth
 - Laser Weaponry
 - Technology reusable in commercial applications
- **Waytronx contract abstract**
 - By DARPA Microsystems Technology Office
 - Projects:
 - Cooling for high performance portable power units
 - Disruptive Manufacturing Technology
 - TEASAT/ONR Array
 - Tactical Laser Technology
- **Corporate Partner – BAE Systems**



WAYTRONX – GASPT2

- **Gas Quality Inferential Measurement Device**

- Proprietary Nature
 - Design & Developed by Subsidiary of British Gas – Advantica
 - Protected by more than 85 granted international patents
 - First intra-pipeline gas quality & interchangeability measurement device
 - Fully certified for installation in EU; US; Asia; and African natural gas facilities
- Target Customers
 - Large Scale Natural Gas Providers
 - BP; Standard Oil; Shell Gas;
 - BG Energy; ExxonMobil
 - Large Scale Natural Gas Consumers
 - Southern California Edison;
 - San Diego Power & Gas;
 - P,G,&E
- Commercialization
 - Separate operating unit
 - Prototype, Certification & Testing Complete [GasPT1]
 - Production & Delivery 3rd Quarter 2010



WAYTRONX – GASPT2

- **GL Industrial Services Group [formerly: Advantica Ltd]**
 - World class technical assurance and consulting company for the energy industry;
 - 6,000 employees in 80 countries;
 - Delivering improvements in safety, reliability, performance and integrity
 - Inventor & patent holder for GasPT2.



- **Contractual Licensing Agreement**

- Announced August 10, 2009
- Exclusive Worldwide
- Patent protection by GL
- Valued at a minimum of \$35,000,000 to \$40,000,000
 - Initial four year term



SUMMARY

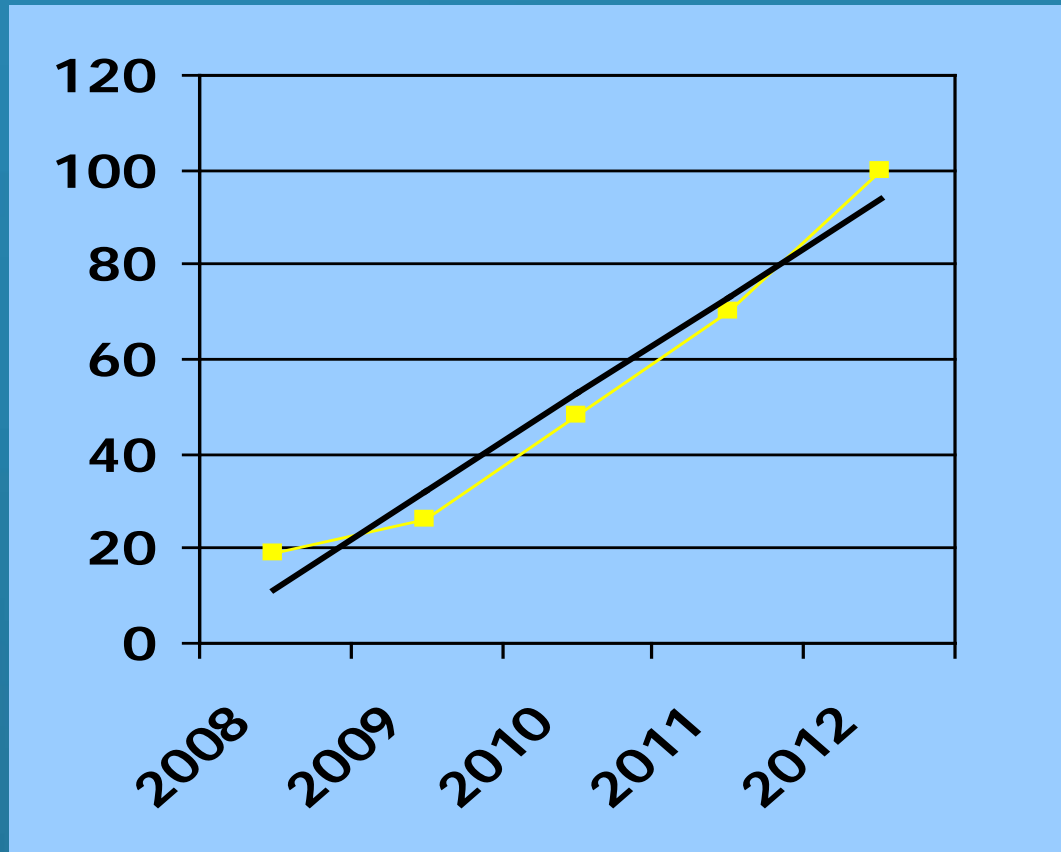

Revenue Growth Trend Line

WWW.WAYTRONX.COM – WWW.CUI.COM

